

# PLATE PRODUCTS REFERENCE GUIDE: QUENCH & TEMPERED PLATE (Q&T) - 80 GRADE

Designation	Weight	Thickness t	Width w	Length l	Designation	Weight	Thickness t	Width w	Length l
	kg/m <sup>2</sup>	mm	mm	mm		kg/m <sup>2</sup>	mm	mm	mm
2500x9600	31.40	4	2500	9600	2485x8000	196.25	25	2485	8000
2500x9600	39.25	5	2500	9600	3100x8000	196.25	25	3100	8000
1525x8000	47.10	6	1525	8000	2485x8000	251.20	32	2485	8000
2485x8000	47.10	6	2485	8000	2485x8000	314.00	40	2485	8000
2485x8000	62.80	8	2485	8000	2485x8000	392.50	50	2485	8000
2485x8000	78.50	10	2485	8000	2485x6000	471.00	60	2485	6000
3100x8000	78.50	10	3100	8000	2000x6000	549.50	70	2000	6000
2485x8000	94.20	12	2485	8000	2000x6000	588.75	75	2000	6000
3100x8000	94.20	12	3100	8000	2000x6000	628.00	80	2000	6000
2485x8000	12.50	16	2485	8000	2000x6000	706.50	90	2000	6000
3100x8000	12.50	16	3100	8000	2000x6000	785.00	100	2000	6000
2485x8000	157.00	20	2485	8000	2000x4300	942.00	120	2000	4300
3100x8000	157.00	20	3100	8000	2000x4300	1099.00	140	2000	4300

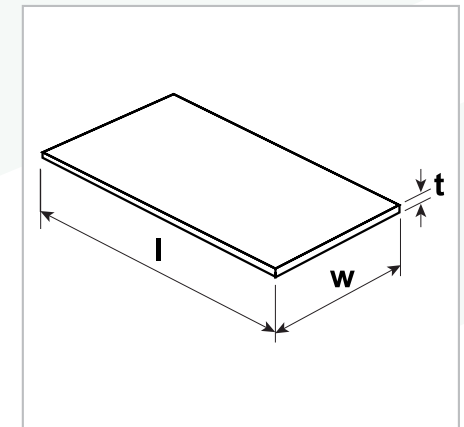

- Manufactured in accordance with the requirements of Australian Standard AS/NZS 3597 in Grade 700.