

# PLATE PRODUCTS REFERENCE GUIDE: QUENCH & TEMPERED PLATE (Q&T) - 450 GRADE

Designation	Weight	Thickness t	Width w	Length l	Designation	Weight	Thickness t	Width w	Length l
	kg/m <sup>2</sup>	mm	mm	mm		kg/m <sup>2</sup>	mm	mm	mm
2500x9300	25.12	3.2	2500	9300	2485x8000	157.00	20	2485	8000
2500x8000	31.40	4	2500	8000	3100x8000	157.00	20	3100	8000
2500x9600	31.40	4	2500	9600	2485x8000	196.25	25	2485	8000
2500x8000	39.25	5	2500	8000	3100x8000	196.25	25	3100	8000
2500x9600	39.25	5	2500	9600	2485x8500	251.20	32	2485	8500
2500x8000	47.10	6	2500	8000	3100x8000	251.20	32	3100	8800
2500x9600	47.10	6	2500	9600	2485x8000	314.00	40	2485	8000
2485x8000	62.80	8	2485	8000	2485x8000	392.50	50	2485	8000
2500x9600	62.80	8	2500	9600	2485x8000	471.00	60	2485	8000
2485x8000	78.50	10	2485	8000	2485x8000	549.50	70	2485	8000
3100x8000	78.50	10	3100	8000	2485x8000	588.75	75	2485	8000
2485x8000	94.20	12	2485	8000	2485x8000	628.00	80	2485	8000
3100x8000	94.20	12	3100	8000	2485x8000	706.50	90	2485	8000
2485x8000	125.60	16	2485	8000	2485x8000	785.00	100	2485	8000
3100x8000	125.60	16	3100	8000					

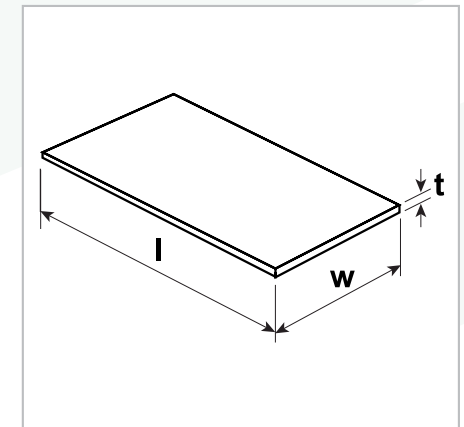

■ Manufactured to manufacturers own internal specifications.