

# PLATE PRODUCTS REFERENCE GUIDE: CLAD PLATE

Designation	Clad Thickness $t^1$	Base Thickness $t^2$	Width $w$	Length $l$	Designation	Clad Thickness $t^1$	Base Thickness $t^2$	Width $w$	Length $l$
	mm	mm	mm	mm		mm	mm	mm	mm
1400x2900	4	6	1400	2900	1400x2900	9	10	1400	2900
1400x2900	6	6	1400	2900	1400x2900	12	12	1400	2900
1400x2900	7	8	1400	2900	1400x2900	17	12	1400	2900

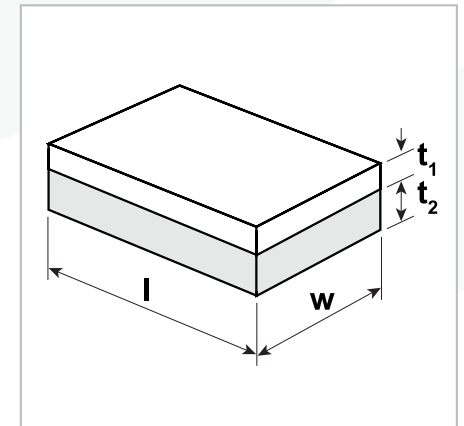

- *Manufactured to manufacturers own internal specifications.*